

Contact Us: **FACTORY UTV LLC.**

9237 Beatty Drive Sacramento, CA 95826

Phone : (916) 383-2730

E-mail : info@factoryutv.net

Go online: [www.Factoryutv.net](http://www.Factoryutv.net)



# Can-Am Maverick X3 Alternate Instructions

*U.H.M.W. Ultra. High. Molecular. Weight. Polyethylene All Terrain Skid Plates & Under Armor Kit For UTV's*

**Hardware** (see back page for hardware pack lists)

**\*Diff**

## Alt. Front UHMW Diff. Skid Plate Instructions :

Install: (2x) J-Clips on to stock main skid: *in ( C ) locations.*

With tip's facing inward toward vehicle, drill out rivet's if needed.

Install: (2x) M6- 1.0 x 20mm Flange Bolts *in Diff. Skid : ( C ) locations.*

*\* Align edge with Main Skid. Mark and \*drill out ( A ) locations.*

(See \*Drilling instructions)

Install: (6x) ¼"-20 x ¾" Self Tapping Bolts *in Diff. Skid : ( A ) locations.*

*(Alt. Diff. Skid will only work in conjunction with OEM Main skid.)*

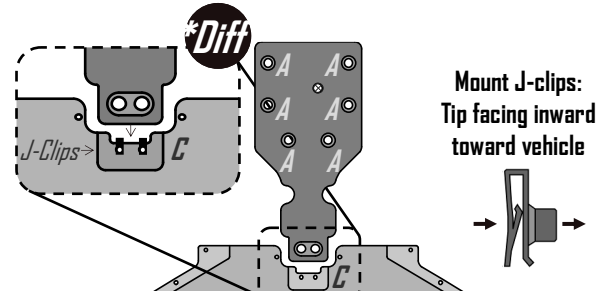

**\*RS**

## Rock Sliders Instructions : (standalone)

\*Drill out Rivets *in main skid : ( A ) locations.* (See \*Drilling instructions) Install each Rockslider on top of OEM skid plate

Install: ¼"-20 x 1¼" Self Tapping Bolts with Counter sunk washers *in main Skid : ( A ) locations.*

Ensure all bolts are fastened securely

(if Rocksliders are to be later installed with FUTV UHMW main skid plate, rocksliders will then mount in-between skid and chassis frame with longer bolts)

( Same steps for 2 and 4 seat models, see back for hardware. )

**\*Rx**

## Rear skid and X-Brace Instructions : (standalone)

\*Drill out (13x) Rivets *in rear skid : ( A ) locations.* (See \*Drilling instructions)

\*Drill out (6x) Rivets *in Main skid : ( B ) locations.* Remove OEM rear skid plate.

Install rear skid plate (whether or not w/ X-Brace) in OEM main skid plate.

( X-brace sits in-between skid & chassis frame, protecting the Transmission )

Align with lip of Main skid plate, you will need to replace rivets in ( B ) locations.

Install: (13x) ¼"-20 x ¾" Self Tapping Bolts with (13x) Counter sunk washers *in Rear Skid : ( A ) locations.*

Ensure all bolts are fastened securely

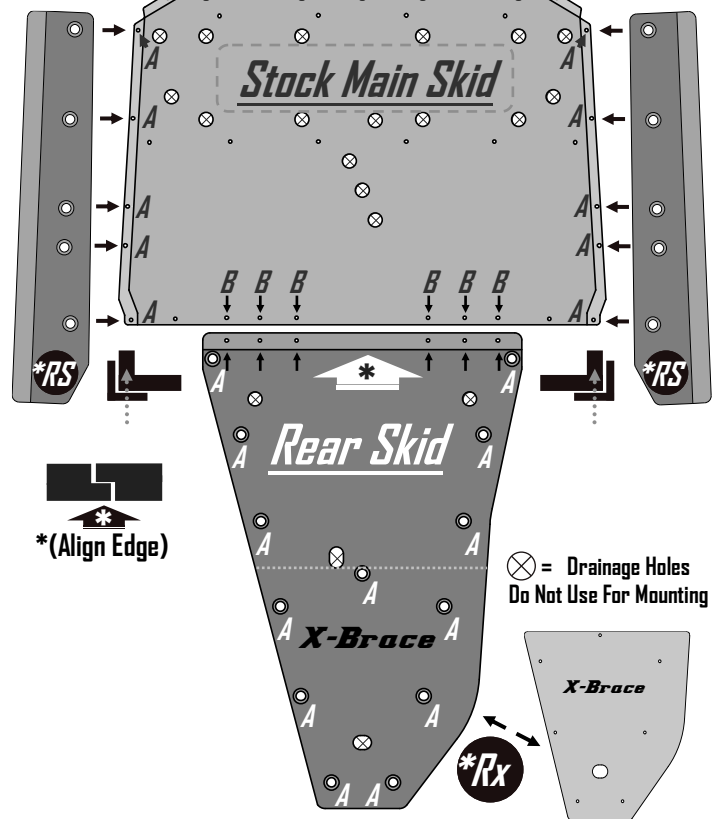

## \*Drilling Instructions : \*

Use a : #Nº7 ( 13/64<sup>th</sup> ) drill bit.

( one size above the commonly available 3/16<sup>th</sup> bit ) Recommend the use of : ¼"- 20 Tap \*(Optional)

To drill and thread self tapping bolts in to chassis frame.

Finger Thread All Bolts Prior To Fastening Securely With Power Tools.

We strongly recommend the use of a "Thread Locking Compound" when installing any mounting hardware.

( When installation is complete , ensure all bolts are fastened securely. )

Contact Us: **FACTORY UTV LLC.**

9237 Beatty Drive Sacramento, CA 95826

Phone : (916) 383-2730

E-mail : info@factoryutv.net

Go online: [www.Factoryutv.net](http://www.Factoryutv.net)



# Can-Am Maverick X3—hardware

*U.H.M.W. Ultra. High. Molecular. Weight. Polyethylene All Terrain Skid Plates & Under Armor Kit For UTV's*

## 2 Seat Rocksliders:

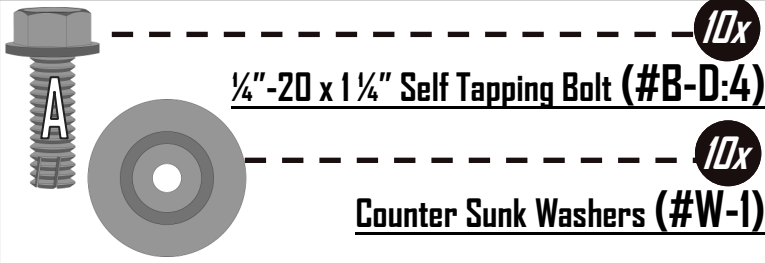

## 4 Seat Rocksliders:

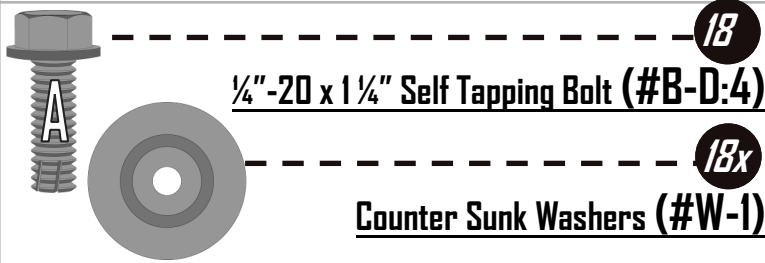

## Alternate Diff Skid:

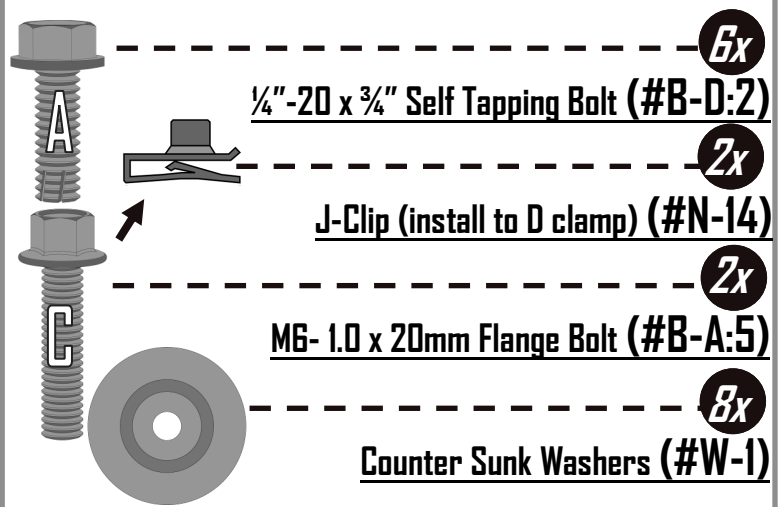

## Standalone Rear Skid Plate:

